



Johnny G Spinner Pro™ and
Johnny G Spinner Elite™ Owner's Manual

www.startrac.com

Table of Contents:

- 1) **Introduction**
- 2) **Fitness Safeguards**
- 3) **Spinner Pro and Elite Features**
- 4) **Assembly Instructions / Parts Callouts / Parts View**
- 5) **Instructions for use**
- 6) **Preventative Maintenance**

Attachment – Warranty Card

1) Introduction:

Thank you for your purchase of the **Star Trac Johnny G Spinner Pro** or **Elite** group cycle bike. The Johnny G bikes will allow you to increase your energy level, increase your cardiovascular and aerobic capacity, increase muscle strength, and decrease your overall percentage of body fat.

This manual is intended to familiarize you with the features, safe operation and maintenance of your **Johnny G Spinner Pro or Elite** models. Please read all applicable section of this manual before assembling, using or servicing your **Johnny G Spinner Pro or Elite** bikes.

2) Fitness Safeguards

These safety notes are directed to purchasers and users of the **Star Trac Johnny G Spinner Pro or Elite** bikes. Club Managers should ensure that members and fitness staff are trained to follow the same safety instructions.

Fitness Safeguards:

- Users should make their physician aware of any proposed fitness regimen before embarking on any exercise program.
- Discuss with your physician any health problems before beginning an exercise program.
- Stop operating the **Johnny G Spinner Pro and Elite** if you feel dizzy, faint or tired.
- Preventative maintenance must be performed in accordance with the guidelines specified under the Preventative Maintenance section of this manual to assure optimum performance of the **Johnny G Spinner Pro and Elite** bikes.
- Keep children and pets away from the **Johnny G Spinner Pro and Elite** bikes while the machine is in use.

Fitness Safeguards (cont.)

Cautions for use of the **Johnny G Spinner Pro and Elite** bikes:

- Persons exceeding 350 lbs may not use this product
- Never attempt to abruptly stop the pedals, especially at high RPM's
- Never remove feet from the **Johnny G Spinner Pro and Elite** bikes while pedals are in motion.
- Do not dismount until the pedals are at a complete stop.
- Do not attempt to ride this bike in a standing position at high RPM's until you have practiced at lower speeds.
- Do not drop or insert any object, hands or feet into any openings or moving parts of the **Johnny G Spinner Pro and Elite** bikes.
- Do not use without proper footwear.
- After exercising, turn the adjustment knob in the positive (+) direction to increase tension so the pedals will not rotate freely.
- Ensure the exercise knobs are secure and do not interfere with exercise.

3) Johnny G Spinner Pro and Elite Features:

- Stainless Steel Components – All exposed metal and hardware are stainless steel for strength and corrosion resistance except for the flywheel.
- Frame – Heavy-duty steel construction with wider stabilizers and larger adjuster feet for maximum stability and durability
- Frame Treatment – The frame is plated then powder coated for the ultimate in corrosion resistance.
- Shrouding – Plastic shrouds cover the brake and chain to deflect perspiration and prevent rust.
- Push Brake System – The quickest way to stop the flywheel of any group cycling bike – just push down on the adjustment knob.
- Pop-pin adjustments – Three turn locking pin
- Saddle – ergonomic saddle for added rider comfort
- Flywheel – Re-engineered perimeter weighted flywheel, offering the same feel that is true to the heritage of the Johnny G Spinner line of bikes.

Johnny G Spinner Pro and Elite Features: (Cont.)

- **Smart Release System™** - **ON THE ELITE MODEL ONLY**
– this allows the benefits of the direct drive system with a safety clutch to release crank from direct drive when a force is applied onto the pedals.

4) Assembly Instructions / Parts Callouts / Parts View

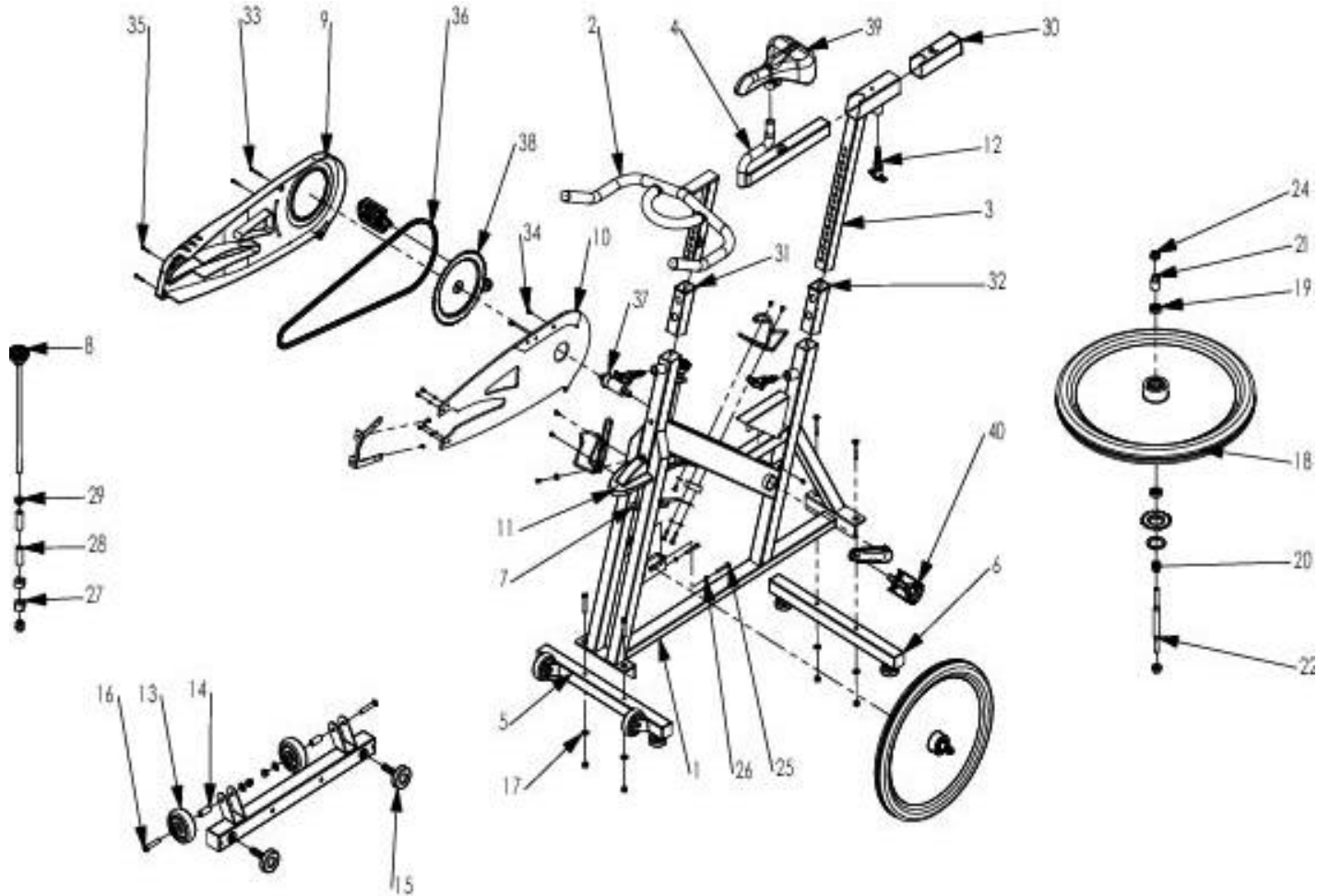

Star Trac Johnny G Spinner Pro

	Part Description	Units Per Bike
1	Frame	1
2	Handlebar Post Assembly	1
3	Seat post Assembly	1
4	Adjustable slide for seat	1
5	Front Leg Assembly	1
6	Back Leg Assembly	1
7	Brake Pad Assembly	1
8	Brake Knob and Bolt Assembly	1
9	Chain Guard(out side)	1
10	Chain Guard(inside)	1
11	Finder	1
12	Pop pin	3
13	New Wheel	2
14	Axle Sleeve for Wheel	2
15	Adjustable foot Pad	4
16	Wheel Bolts	2
17	Washer for front leg	2
18	Flywheel w/hub, Label and Chain ring	1
19	Bearing for Flywheel 6000zz	2
20	Right Axle Spacer	1
21	Left Axle Spacer	1
22	Flywheel Axle	1
23	Spring for brake pad	1
24	Flywheel axle nut	2
25	Chain tension Adjustment Bolt	2
26	Chain tension lock nuts	2
27	Brass Nut	1
28	Plastic Sleeve	2
29	Plastic Bushing	1
30	Sleeve for seat slide	1
31	Handlebar sleeve	1
32	Seat post sleeve	1
33	Chain Guard Bolts-Long	1
34	Chain Guard Bolts-Short	2
35	Chain Guard Bolts-Medium	3
36	Chain	1
37	Bottom Bracket	1
38	Cranks (Set)	1
39	Seat	1
40	Pedals (Set)	1

Parts List for Star Trac
Johnny G Spinner Pro

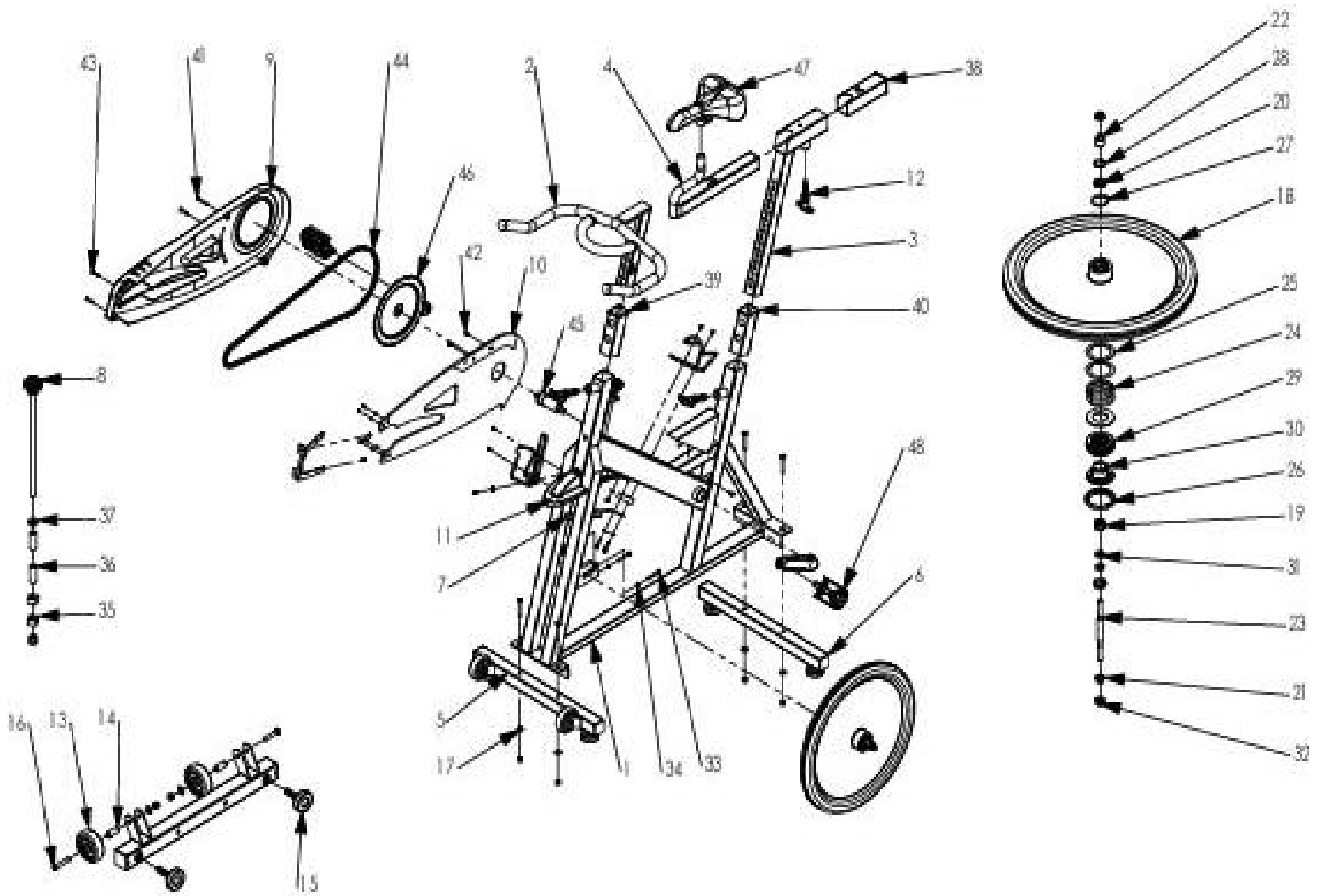

Star Trac Johnny G Spinner Elite

	Part Description	Units Per Bike
1	Frame	1
2	Handlebar Post Assembly	1
3	Seat post Assembly	1
4	Adjustable slide for seat	1
5	Front Leg Assembly	1
6	Back Leg Assembly	1
7	Brake Pad Assembly	1
8	Brake Knob and Bolt Assembly	1
9	Chain Guard(out side)	1
10	Chain Guard(inside)	1
11	Finder	1
12	Pop pin	3
13	New Wheel	2
14	Axle Sleeve for Wheel	2
15	Adjustable foot Pad	4
16	Wheel Bolts	2
17	Washer for front leg	2
18	Flywheel w/hub, Label and Chain ring	1
19	Right bearing for flywheel NK11016	1
20	Left Bearing for Flywheel 6000zz	1
21	Right Axle Spacer	1
22	Left Axle Spacer	1
23	Flywheel Axle	1
24	Spring for brake pad	1
25	Gasket for Flywheel	1
26	Aluminum cap	1
27	C Ring for hub on flywheel	1
28	C Ring for bearing on flywheel	1
29	Chain ring with bearing	1
30	Clutch Axle	1
31	Bearing locking nut	2
32	Flywheel axle nut	2
33	Chain tension Adjustment Bolt	2
34	Chain tension lock nuts	2
35	Brass Nut	1
36	Plastic Sleeve	2
37	Plastic Bushing	1
38	Sleeve for seat slide	1
39	Handlebar sleeve	1
40	Seat post sleeve	1
41	Chain Guard Bolts-Long	1
42	Chain Guard Bolts-Short	2
43	Chain Guard Bolts-Medium	3
44	Chain	1
45	Bottom Bracket	1
46	Cranks (Set)	1
47	Seat	1
48	Pedals (Set)	1

Parts List for Star Trac
Johnny G Spinner Elite

Assembly Instructions:

- A) Secure the front brace with wheels (#5) and the rear brace (#6) to the frame (#1) by using four hex bolts, eight washers, and four lock nuts. Note – the washers must be placed above and below the brace.
- B) Attach the pedals using the multi hex wrench. Note that the closed end to of the cage must point to the front of the bike in order to go on the correct side of the crank. Also note that the left pedal has lefthanded threads and must be tightened counter clockwise.
- C) Insert the seat post (#3) into the frame (#1) and secure with a locking pop pin (#12)
- D) Insert the handle bar (#2) into the head tube of the frame (#1) and secure with a locking pop pin (#12)
- E) Mount both bottle cages with the stainless steel allen screws. Note that the screws may be secure in the frame, and will need to be removed prior to placing the water bottle holder onto the bike.

5) Instructions for use:

Resistance – Pedaling resistance is controlled by the push Brake System Knob located underneath the handlebars. To increase resistance, turn the Brake System Knob clockwise (+). To decrease resistance, turn the resistance counter-clockwise (-). Resistance adjustments can be done while riding.

Seat Adjustment – Place one pedal in the upward position, then place your foot in the toe clip and center the ball of your foot over the center of the pedal. Your leg should be slightly bent at the knee. If your leg is too straight or your foot cannot touch the pedal, you will need to move the seat down. If your leg is too bent, you will need to move the seat up.

To adjust the seat up or down, dismount the bike and loosen the locking pop-pin by turning the handle counter-clockwise. Pull out the spring-loaded knob, from the preset location. Raise or lower the seat to the desired height, and release the pop-pin. When the correct location is detected, tighten the pop pin by tightening clockwise.

Seat Adjustment (Cont.)

To adjust the forward or backward (i.e. for and aft) seat position, dismount the bike and loosen the locking pop pin by turning counter clockwise. Pull out the spring-loaded release knob, releasing the locking pin from the pre-set position hole. Slide the seat forward or backward to the desired position. When the seat is in the desired position, release the spring-loaded mechanism to re-position the locking pin into the desired location. Turn the handle clockwise to tighten the pop pin.

Handlebar Adjustment – To raise or lower the handlebars, loosen the locking pop pin. Pull out the spring-loaded release knob. This releases the locking pin from the pre-set position. Raise or lower the handlebars to the desired position. When the handlebars are in the desired position, release the spring-loaded knob re-positioning the locking pin in the desired, pre-set hole. Turn the handle clockwise to tighten the knob.

Pedal Strap Adjustment – Place the ball of each foot in the toe clip until the front of the shoe fits snugly in the toe clip cage. Rotate one foot to within arm's reach, then tighten the webbed cloth buckle until the cage of the toe clip is snug around the foot. Repeat for the other foot. Point your toes and knees directly forward to ensure maximum pedal efficiency.

6) Preventative Maintenance:

Moving the Johnny G Spinner Pro and Elite: Utilize the front wheels on the front brace to roll the bike from one location to another.

Leveling the bikes: All four pads that the bikes rest on (#15 in drawings above), can be adjusted to compensate for a non-level floor. Place the bike on its side and rotate the foot either clockwise or counter clockwise to level the bike depending upon situation.

Daily Maintenance: Dry the Johnny G Spinner Pro and Elite after each use to remove sweat and moisture. It is best to use a liquid non-abrasive cleaner and water solution.

Rinse all surfaces to remove detergent residue and then dry. Do not wipe the chain with soap or towel. Avoid wetting the brake pad when cleaning.

Preventative Maintenance (Cont.)

Daily Maintenance (Cont.)

IMPORTANT – To avoid damaging the finish on your Johnny G Spinner Pro and Elite, never use a petroleum-based solvent for cleaning.

Periodic Inspection: The crank arms should be re-torqued after the first 10 hours of use and every 100 hours of operation, thereafter. The crank arm to bottom bracket torque is 30 ft-lbs (+/- 3 ft-lbs). Using a 15 mm wrench, the pedal should be snug.

Inspect all parts, nuts and screws for any adjustments, replacement or maintenance needs.

It will be necessary to lubricate the chain once a month or after every 100 hours of use, whichever comes first. The chain should be lubricated with a light chain oil, using a bristle brush.

To learn more about adjustments and replacements, please contact the Star Trac service department at (800) 503-1221 or you can contact us at (714) 669-1660.

